



***Alignment
pins now
with track***

E Series Assembly Manual

info@ibeamdoor.com Phone: 815-945-3667 Fax: 815-945-7073

Recommended Safety Equipment & Attire: Hard hat, leather gloves, safety glasses, work boots, long sleeve shirt, & pants. **No loose clothing.*

Recommended Tools: tape measure, hammer, 5/16 nut driver, hammer, aviation snips, ear plugs, various wrenches & sockets; 3/8", 7/16", 1/2", socket extension, pliers, battery operated drill driver, & a pencil.

Legal Disclaimer:

I-Beam Sliding Doors will not be held responsible for any incidents or accidents that occur before, during, or after the assembly of the door. I-Beam Sliding Doors is not responsible for damaged materials or injuries to persons, and damage throughout unloading or building process.

Warranties:

10 year-110 MPH wind warranty. Warranty only covers damage done when doors are latched in either the closed or open position. Warranty does not cover improper assembly and installation of components.

I Beam Sliding Doors Assembly Instructions

Door Frame Assembly

1. Lay vertical door frames (**#31**) and slide girts (**#32**) in top/bottom and evenly spaced throughout door panel. All E series girts have long tabs from web towards the bottom of door. Make sure verticals have center mechanism holes towards bottom of door, 41" bottom hole to bottom of vertical.
2. Install (**#4**) top and bottom (**#5**) C brackets for trolleys centered over trolley hole, slotted bracket (**#4**) goes on bottom and single hole (**#5**) goes on top. The brackets get fastened on the inside of the top frame girt. Make sure pre-drilled holes are towards the inside of the frame.
3. Install trolley into top frame with B20 (**#7**) adjustment plate and flange nut with jamb nut, to not tighten nuts on bolt until door is adjusted where it's needed; after door is hung and trolleys are adjusted, install screws into (**#7**) trolley adjustment washer and tighten lock nut (**#9**).
4. Bolt on the latch mechanism, as shown in the latch view drawing, to the pre-drilled vertical I Beam with 1/4" x 1" bolts (**#21**). The latch assembly is reversible so it operates in both directions. On a double sliding door one of the interior handles will be backwards so the handle will need to be removed and turned in the opposite direction so when the door is in the un-latched position the interior handle is up.
5. Drill a hole in the center of the top rail for bolt and chain hook-up to hang large doors with a boom or crane.

Track and track board

1. Nail on 2x4 or 2x6 track board onto door header and track header every 6-8" in a zigzag pattern using 16D nails. We recommend a 2x6 thru the opening then a 2x4 beyond. The track is the same width as the door beyond the opening, and the track board is nailed 9½" + door size from bottom of skirt (16' door + 9½" = 16'-9½" from bottom of skirt or 16'4" opening to bottom of building skirt). Lag on track with 5/16" x 2 ½" lags (top mount track) (**#1**) thru the pre-drilled holes in the track. On large doors we recommend nailing track board 6" OC.

Steel and Trim

1. For best results, trim out and lay sheet panels while door is on 4 saw horses. Start by marking the girts on exposed verticals where screw rows are needed, advise not to screw thru web of girt.
2. Start steel against center latch side. Rip sheet down center of first rib or rip completely off for clearance of trim and center latch exterior handle; do same on dead end of door for clearance of trim
3. Cut out a hole for exterior latch handle in-line with the latch mechanism hole. Fasten handle with ¼" rubber gasket (**#26**) between steel siding and B11(**#25**) spacer plate , then handle into E4 (**#27**)latch bracket with 3) 12 x 1 1/2" self-tap screws(**#20**). (Do not over-tighten screws and might need to work screw tension to get handle to operate freely)
4. Mark the vertical frame cover trim where steel panels need to be screwed on the I Beam girts. We recommend fastening the panels so the screws cannot be seen on the inside from the ground. To accomplish this, marks need to be on the bottom side of the web on bottom 2 girts and the top side of the web on remaining upper girts.
5. Before fastening steel make sure door panels are square by measuring from corner to corner. **NEVER FASTEN DOOR PANELS THROUGH THE RIB OF THE STEEL, ALWAYS FASTEN IN FLATS BESIDE RIBS.** Doors diaphragm wind design only allows for steel to be fastened in the flat on E series doors. Steel panel lengths should be in even footage length per door height. (Example, 16' door = 16' door steel.) We recommend using a "Z" wainscot or square base trim.
6. Make sure door is square before fastening steel to frame by measuring corner to corner. Fasten around the perimeter of the door and as far as you can reach in the center, after door is hung finish fastening remaining screws in center. **Never walk on a door panel to fasten steel; walking on shavings scratches and your added weight bows the frame permanently as your installing screws.**
7. Install top J trim with angled weather leg and slide J behind steel and fasten in the flat of the rib.

8. Vertical frame cover starts at the bottom of the metal then is notched on the side of the door flush with the bottom of the vertical I Beam. The top of the vertical frame cover is cut flush with the top of the hat trim. Vertical frame cover gets installed by overlapping steel, and screwed thru the face of the door frame towards the center of the door, and on the side leg of vertical E girt.

9. ***Do Not leave doors on flat surface and let water or precipitation set on steel; steel shavings will rust the metal!** Build and hang doors on same day, or lay them indoors to keep them out of the weather to prevent rust spots from the shavings.

Hanging and Final Assembly

***We advise NOT to hang doors in windy conditions!**

1. Depending on door size, use a boom or piece of equipment to lift door from the center of panel with a 1/2" bolt thru a chain and thru the top girt center hole. Slide door trolleys (#6) in track then adjust trolleys to the proper height and clearance away from header; make sure doors are flush top to bottom on jambs and flush when slid together in the center.

2. Drill a post hole minimum 4' deep and fill with concrete; wet set center door guide bracket in concrete 1 1/2" outside of the building to the inside of the bracket and exactly centered in the opening. Allow concrete to cure before doors get latched shut, leave open for 24 hours, Make sure doors are secured open.

For ultimate results make a concrete sill footing through the opening with a steel angle lip on the inside, this makes doors much easier to use and maintain. Please dig hole or trench min. 6" be low frost depth.

3. Tighten locking nuts on trolleys and make sure 4) 10 x 1" self-tap screws are into the trolley adjustment bracket (#7). 3. Remove cotter pin and washer from latch mechanism (#23) farthest from the door frame and install latch rod thru the bottom girt and thru the bottom of the door frame.

4. Bolt on E6 Jamb Clincher bracket (#11) to the bottom of the skirt board using 2) 3/8" x 4" lag bolts (#10).

5. Install door guide rollers (#15 & #17) to the side of skirt or side of concrete

foundation with 5/16" lag screws or concrete anchor bolts. Make sure there's at least a 3/4" clearance between top of roller and bottom of C web. 1st roller from opening goes 18" center than 2' to the next than 3' to the next, than spaced 4-5' OC depending on door length. Adjust in/out for optimal operation.









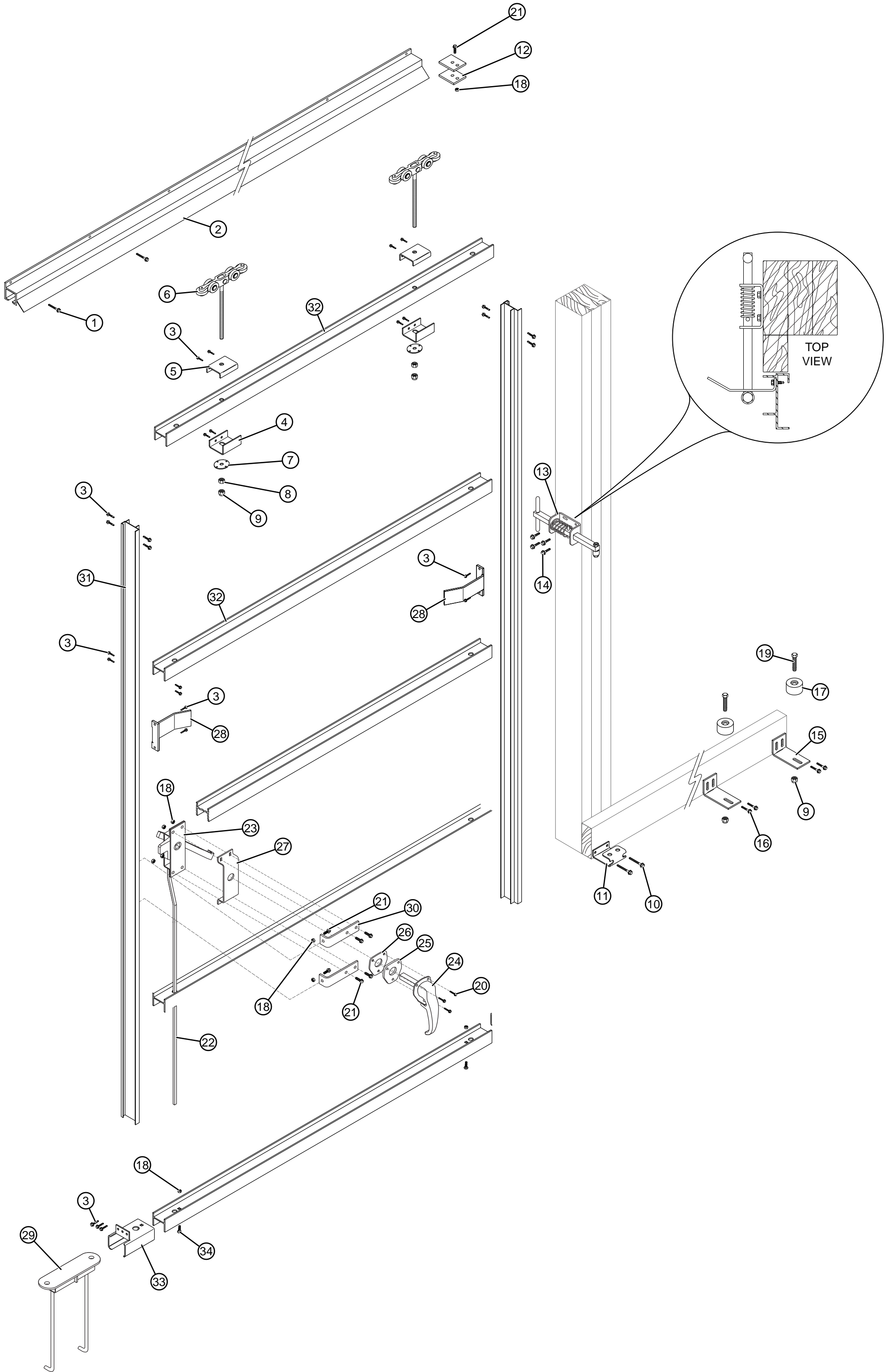

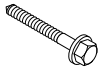

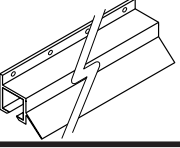



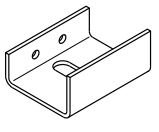

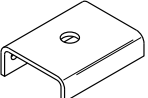
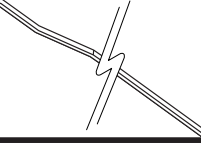
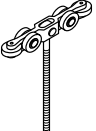
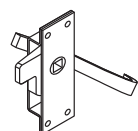

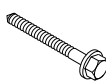

6. Install Door track stops B22 (**#12**) on end of track.
7. Operate the door open and close, make sure door latches in closed and open position properly and everything operates smoothly.

Jamb Latch Assembly

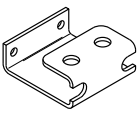
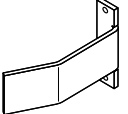
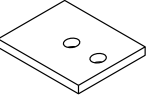
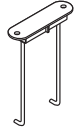
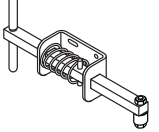
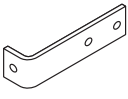
*Doors need to be adjusted and level before installing.

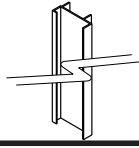
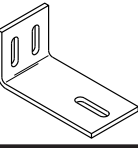
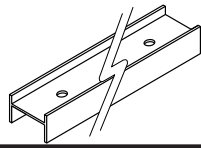
1. Field locate jamb latch ramp (**#28**) above center latch handle vertical frame (when door is closed on jamb side) in the neighborhood of 60" from bottom of C channel. Fasten flat hole side of jamb latch ramp (**#28**) tight against inside of jamb vertical frame (**#31**) with 4-#12x1" tek screws (**#3**).
2. Install jamb latch assembly (**#13**) loosely with 2) ¼ x1 ½ lags (**#14**) in slotted holes w/roller against clincher. Open door slightly to slide jamb latch assembly ¼" into building for snug fit; tighten & install 2 remaining lag bolts.
3. Open door to locate & install jamb latch ramp (**#28**) to central vertical frame centered on Jamb latch roller. Install other ramp at the same height onto center vertical on split doors, opposite direction of jamb side ramp; install jamb latch and clincher on other door panel with ramps and latch at same level.

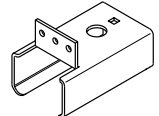

1		5/16" x 2 1/2" Lag Bolt	18		1/4" Flanged Nut
2		Ultra Glide Track	19		1/2" x 2 1/2" Hex Head Bolt
3		#12 x 7/8" Tek Screw Fine Thread	20		#12 x 1 1/2" Tek Screw
4		E11 Bottom Hanger Adjustment Bracket	21		1/4" x 1" Flanged Bolt
5		E12 Trolley Hanger Bracket	22		48" Latch Rod
6		Ultra Glide Trolley	23		Center Latch Assembly
7		B20 Trolley Adjustment Washer	24		Standard Exterior Handle
8		1/2" Standard Nut	25		B11 Exterior Handle Spacer
9		1/2" Nylock Nut	26		1/4" Rubber Gasket
10		3/8" x 4" Lag Bolt	27		E4 Exterior Handle Mount Bracket
11		E6 Jamb Clincher Bracket	28		B18 Jamb Latch Ramp Bracket
12		B22 Track Stop	29		B5 Tabbed Center Door Guide Bracket
13		Jamb Latch Assembly (Spring Loaded)	30		B3 Center Assembly Mounting Bracket
14		1/4" x 1 1/2" Lag Bolt	31		Vertical Frame 4 1/4" x 2" Aluminum
15		B23 Roller Guide Bracket	32		Horizontals (Girts) 2 3/4" x 1 3/4" Aluminum
16		5/16" x 1 1/2" Lag Bolt	33		E14 Channel Cover
17		Nylon Roller	34		1/4" x 3/4" Carriage Bolt

E SERIES ASSEMBLY I-BEAM DOORS DOOR ELEVATION

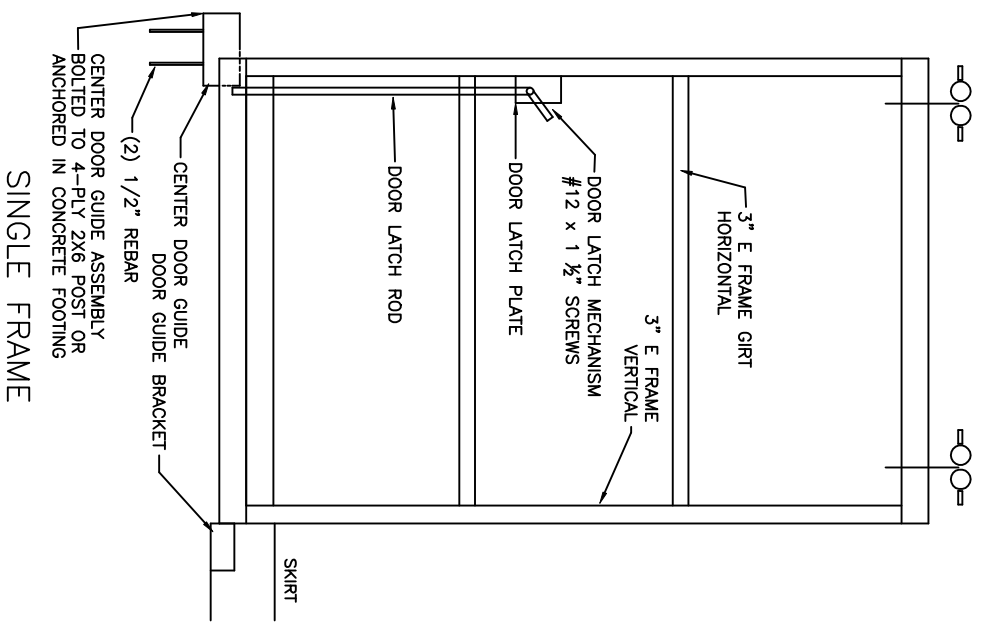
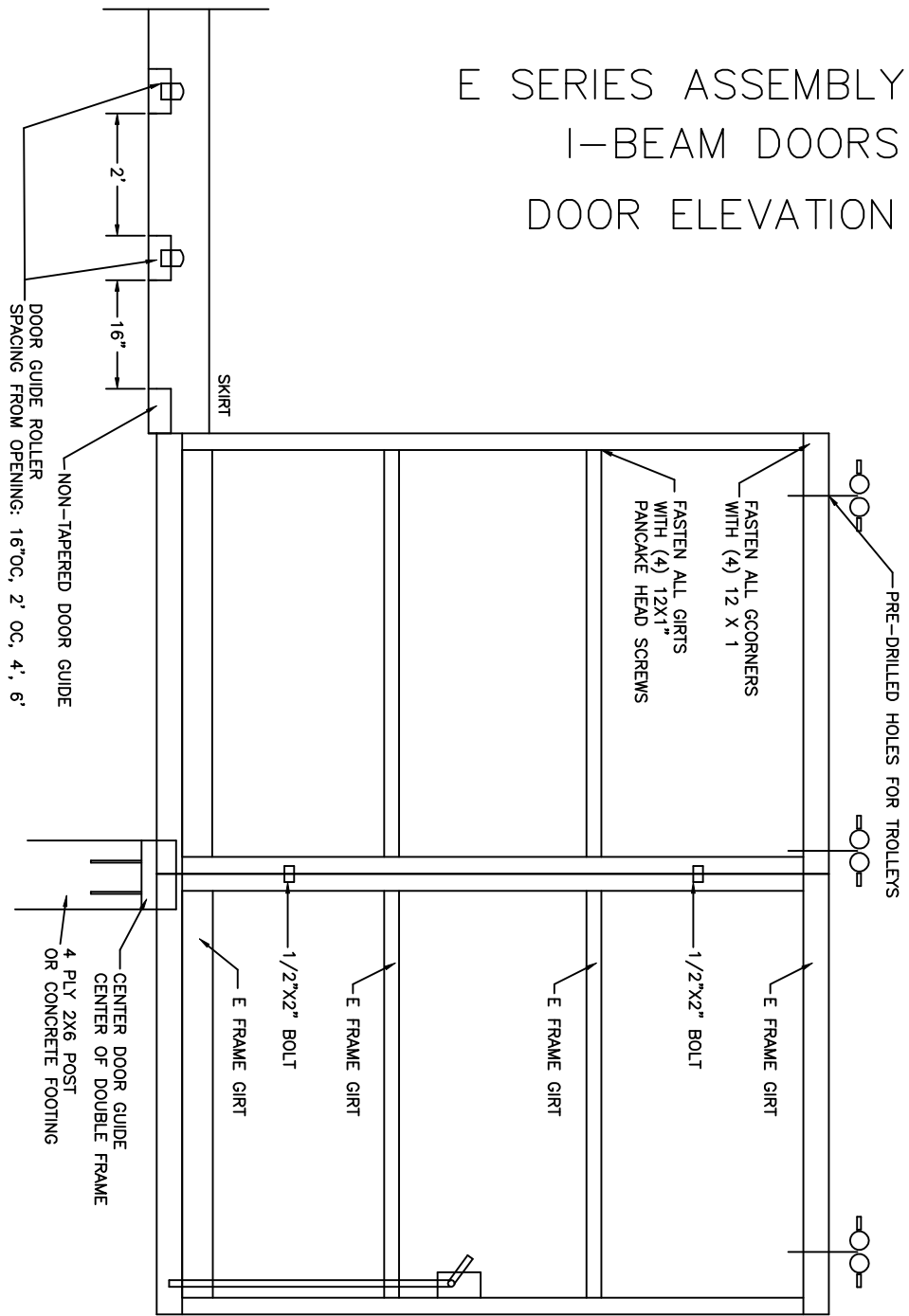

E SERIES ASSEMBLY
 I-BEAM DOORS
 DOOR SECTION

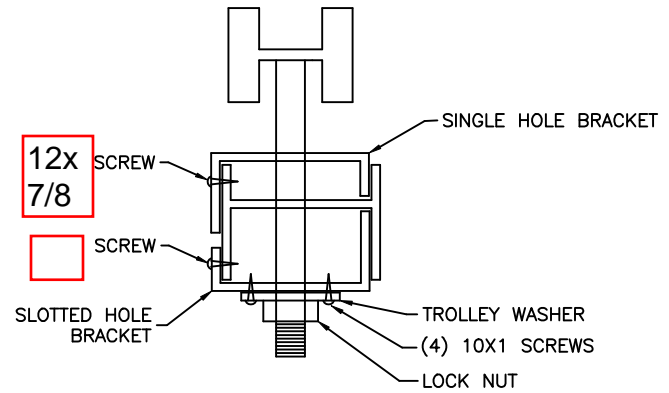
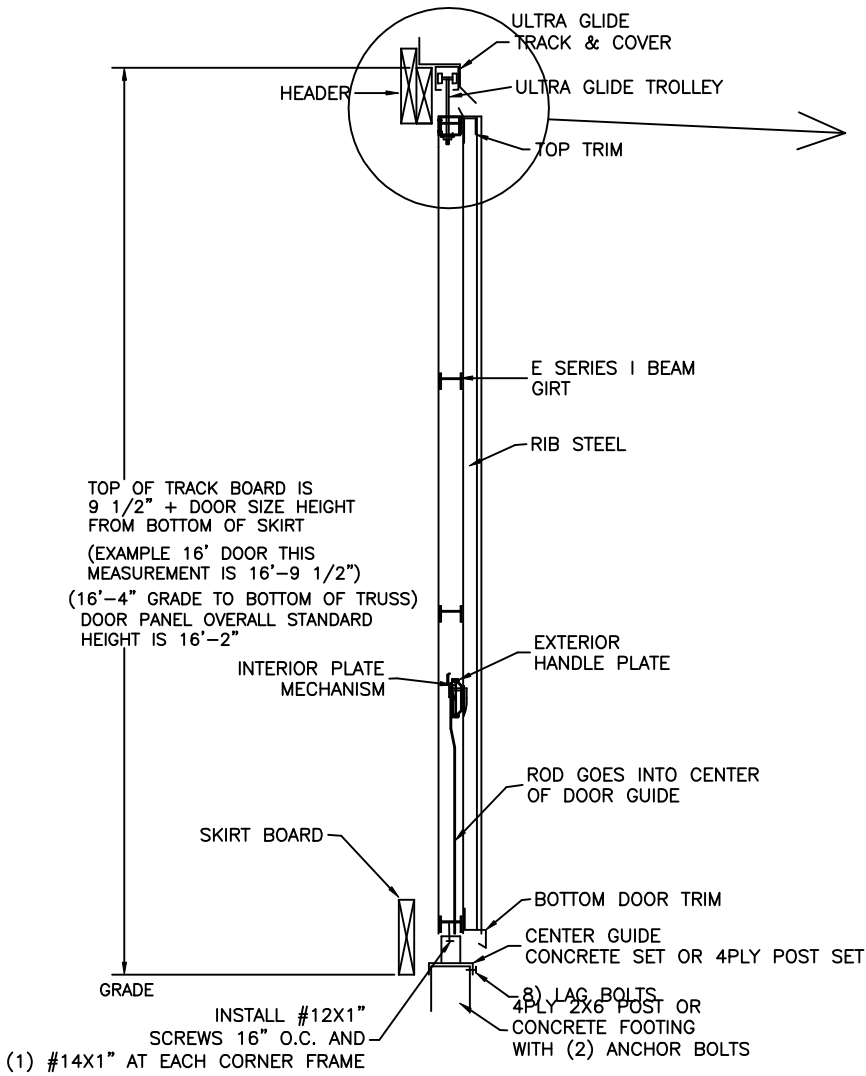

E SERIES TRIM
I-BEAM DOORS
TRIM PROFILES

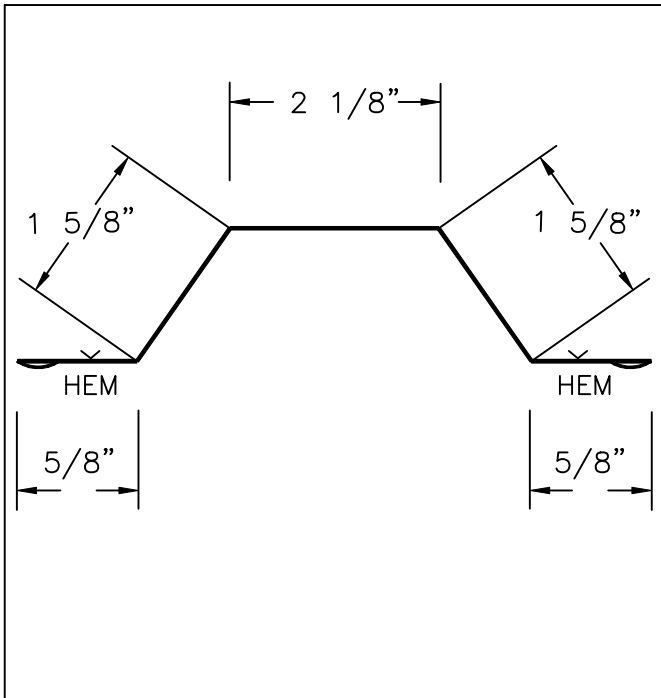

DOUBLE FRAME COVER

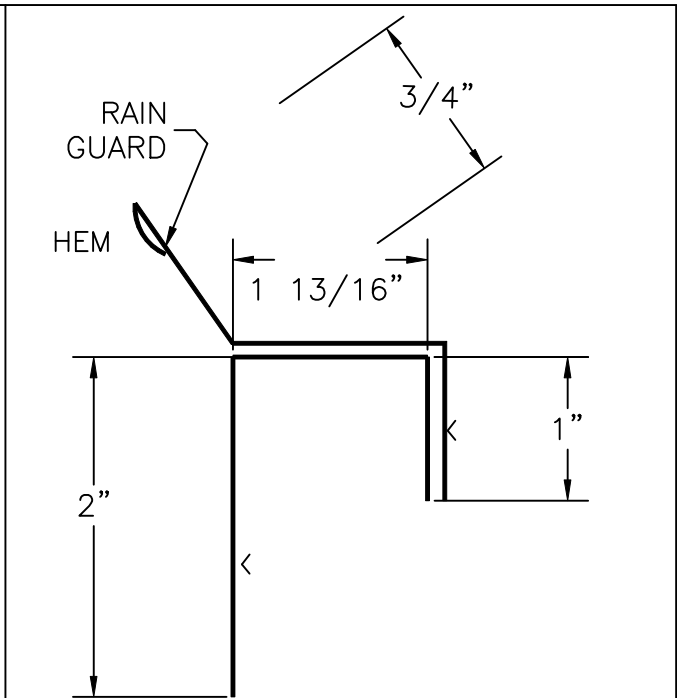

TOP TRIM

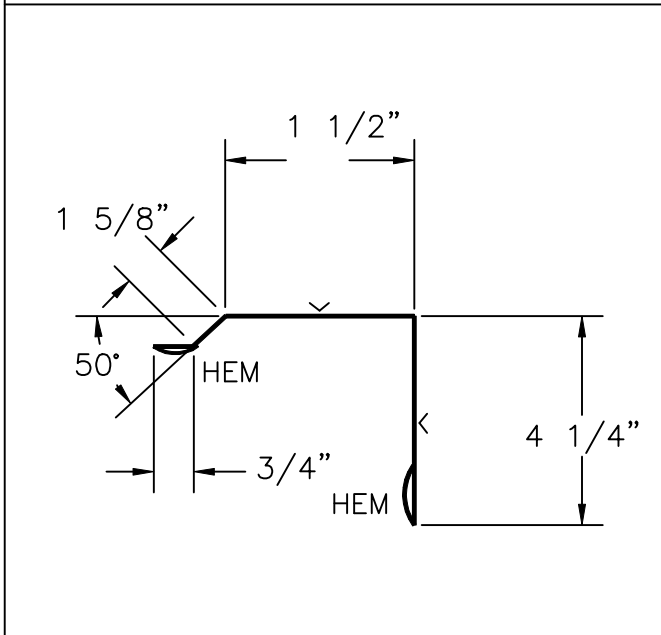

VERTICAL FRAME COVER
ENDS - INTERMEDIATES

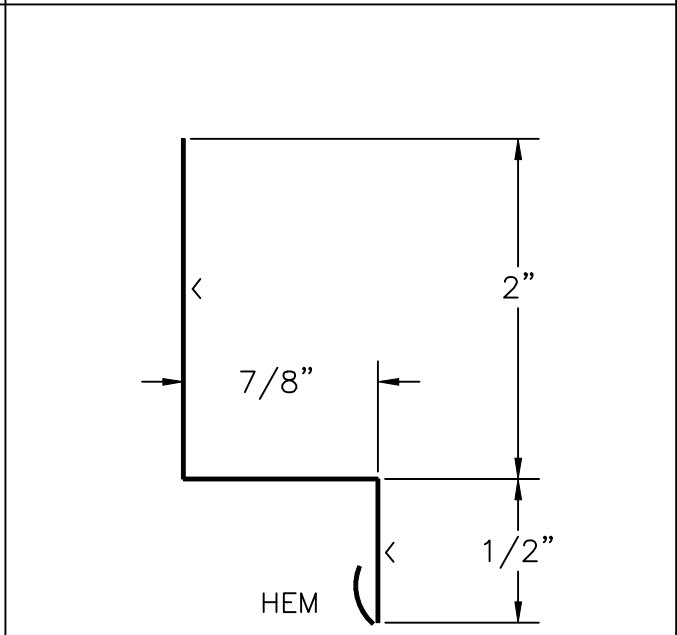

BOTTOM DOOR TRIM
(WAINSCOT TRIM)

INDICATES PAINTED SIDE

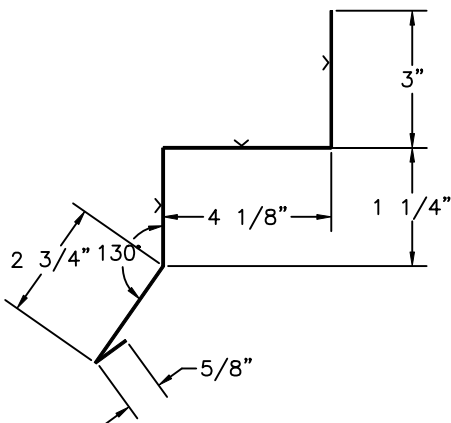

ULTRA GLIDE TOP
MOUNT TRACK COVER

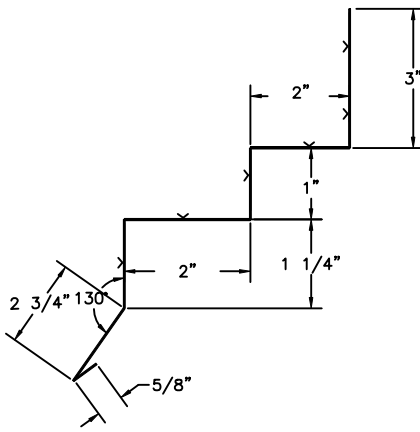

ULTRA GLIDE FACE
MOUNT TRACK COVER

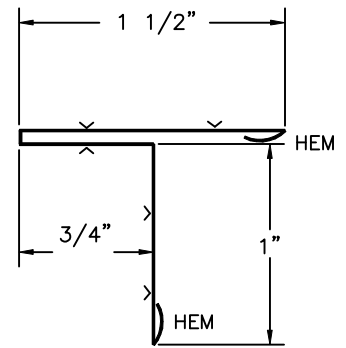

CENTER "T" TRIM

E-Series Girt Spacing measuring from bottom of Verticals

8' = 32" O.C.

10' = 30" O.C.

12' = 28.8" O.C.

14' = 28" O.C.

15' = 30" O.C.

16' = 32" O.C.

17' = 29.1" O.C.

18' = 31" O.C.

20' = 30" O.C.